



**“H” Series**  
HECO Interchange Series  
**Power Wheel<sup>®</sup>**  
**Planetary Gear Drive**



## CONTENTS

<b>Introduction</b>	<b>3</b>
<b>Auburn Gear, Inc. versus HECO - Gear and Bearing Ratings Comparison</b>	<b>4-5</b>
<b>Model 6 Center Flange Shaft Output Drives - Single Reduction - 16CF</b>	<b>6-7</b>
<b>Model 6 Front Flange Shaft Output Drives - Single Reduction - 16FF</b>	<b>8-9</b>
<b>Model 8 Center Flange Shaft Output Drives - Single &amp; Double Reduction - 20CF &amp; 20DCF</b>	<b>10-11</b>
<b>Model 8 Front Flange Shaft Output Drives - Single &amp; Double Reduction - 20FF &amp; 20DFF</b>	<b>12-13</b>
<b>Model 6 &amp; Model 8 Shaft Output Options</b>	<b>14</b>
<b>Lubrication Data / Warranty Information</b>	<b>15</b>



Why choose **AuburnGear** over your current planetary drive supplier?

A worldwide dedicated fluid power distribution network to help serve customers' technical and service needs



More than 60 years of gear manufacturing experience at the Auburn, Indiana facility



300 dedicated employees who work together to satisfy customer wants and needs



A high level of technical support at Auburn Gear and at the distribution level



After sales literature and parts program that provides rapid customer service



Excellent value: competitive pricing, Power Wheel products that perform and are reliable, and delivered on a JIT basis

**= Auburn Gear  
Power Wheel®  
Planetary  
Gear Drives**

*(The Compelling Choice)*



# Gear Ratings - *AuburnGear* versus HĒCO



Per the HĒCO, Inc. catalog, the maximum torque listed for each HĒCO model is a continuous torque based on a 2000 hour B10 life at output speeds less than the published maximum.

The charts below provide a direct comparison of the HĒCO Model 16 versus the Auburn Gear Model 6H and the HĒCO Models 20 and 20D versus the Auburn Gear Model 8H.

## Ratings Comparison

Manufacturer Model	Continuous Output Torque (lb-in)	Max Output Speed (RPM)
HĒCO 16	27,500	350
Auburn Gear 6H	34,000*	700**

\* The 34,000 lb-in continuous output torque rating is based on a 2,000 hour B10 life at an output speed less than the published maximum.

\*\* It can be expected that applications requiring a combination of high output torque and high output RPM will result in shortened reducer life.

## Auburn Gear Advantages: 6H versus HĒCO Model 16

- Greater output torque rating will provide; (1) increased gear life under the same torque load conditions or (2) provides the user the ability to incrementally increase the torque requirement without a loss in gear life when comparing the 6H to the HĒCO Model 16.
- Greater output speed rating allows the user to incrementally increase the speed without loss in gear life when comparing the 6H to the HĒCO Model 16.

## Auburn Gear Advantages: 8H versus HĒCO Models 20 and 20D

- Greater output torque rating will provide; (1) increased gear life under the same torque load conditions or (2) provides the user the ability to incrementally increase the torque requirement without a loss in gear life when comparing the 8H to the HĒCO Model 20 and 20D.
- Greater output speed rating allows the user to incrementally increase the speed without loss in gear life when comparing the 8H to the HĒCO Model 20 and 20D.

## Ratings Comparison

Manufacturer Model	Continuous Output Torque (lb-in)	Max Output Speed (RPM)
HĒCO 20	60,000	300
Auburn Gear 8H Single Reduction	80,000*	600**
HĒCO 20D	60,000	100
Auburn Gear 8H Double Reduction	80,000*	160**

\* The 80,000 lb-in continuous output torque rating is based on a 2,000 hour B10 life at an output speed less than the published maximum.

\*\* It can be expected that applications requiring a combination of high output torque and high output RPM will result in shortened reducer life.

# Bearing Ratings - AuburnGear 6H versus HECO 16

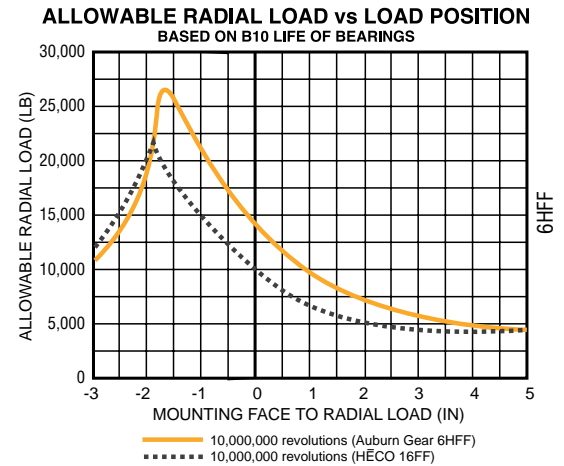
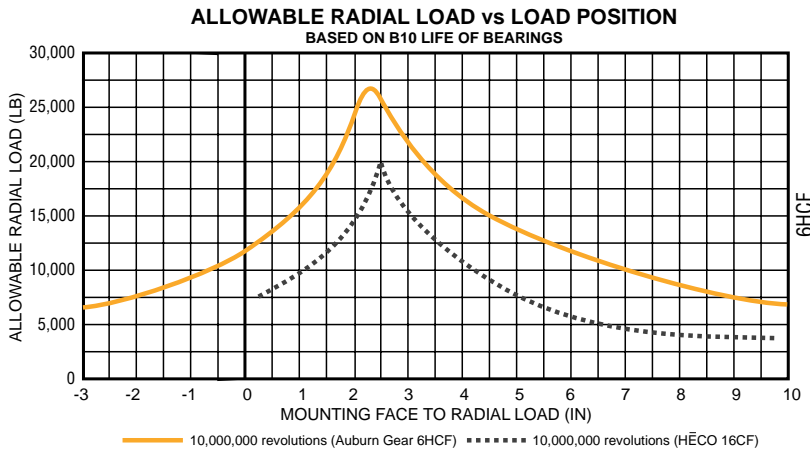

## Ratings Comparison

Manufacturer Model	Max.Radial Shaft Load (lb)
HECO 16	21,000
Auburn Gear 6H	26,000

## Auburn Gear Advantages: 6H versus HECO Model 16

- Greater radial load rating, regardless of load center, will provide;
  - (1) longer bearing life under the same loading conditions or
  - (2) the same bearing life by comparison under incrementally larger radial loads.

# Bearing Ratings - AuburnGear 8H versus HECO 20

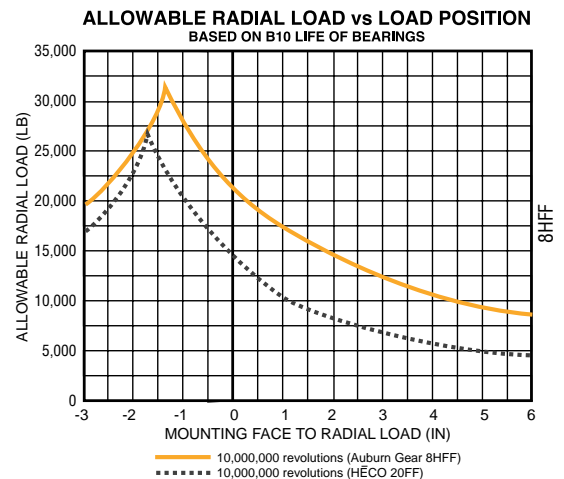
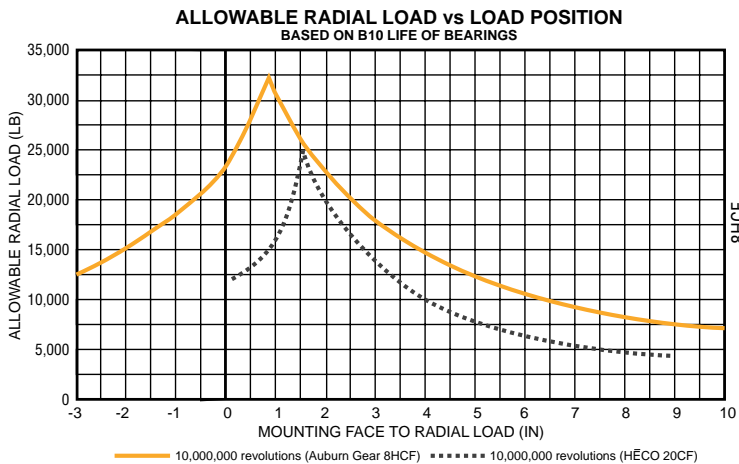

## Ratings Comparison

Manufacturer Model	Max.Radial Shaft Load (lb)
HECO 20	25,000
HECO 20D	25,000
Auburn Gear 8H	32,000

## Auburn Gear Advantages: 8H versus HECO Models 20 and 20D

- Greater radial load rating, regardless of load center, will provide;
  - (1) longer bearing life under the same loading conditions or
  - (2) the same bearing life by comparison under incrementally larger radial loads.



# Model 6 Center Flange Shaft Output Drives - Single Reduction

## GENERAL SPECIFICATIONS

Max. continuous output torque <sup>1</sup> . 34,000 lb-in (3,800 Nm)	Approximate weight 6HCF ..... 61 lbs (26.7 kg)
Max. output speed (RPM) ..... 700	Approximate oil capacity ..... 17 oz (500 cc)
Max. radial shaft load ..... 26,000 lb (11,800 kg)	

<sup>1</sup> The maximum torque listed is a continuous torque based on a 2000 hour B10 life at output speeds less than the published maximum. It can be expected that applications requiring a combination of high output torque and high output RPM will result in shortened life. Contact Auburn Gear with your duty cycle information and we will supply life calculations for your specific application.

Dimensions given in: INCHES (mm)

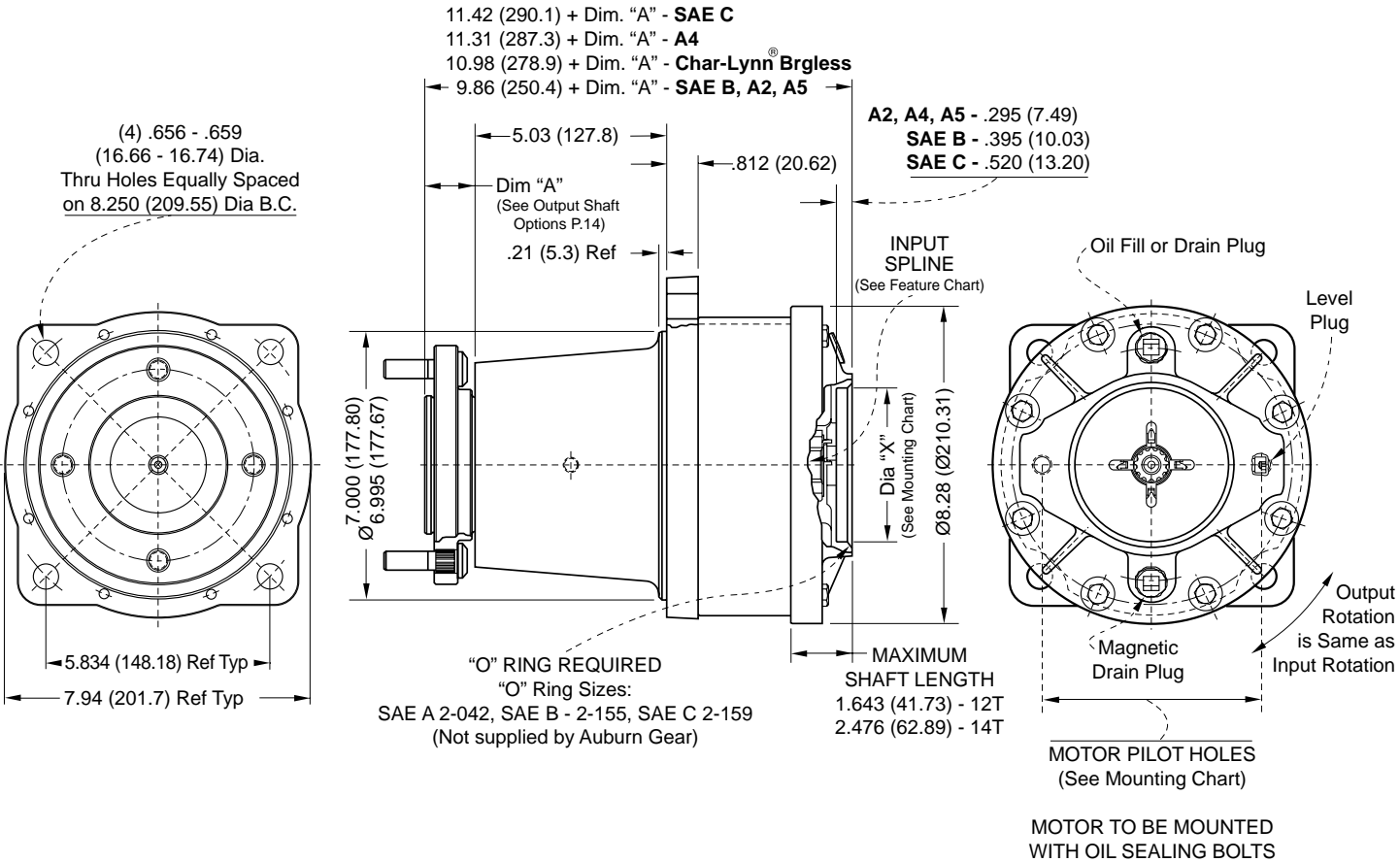

Direct Interchange for:  
 HECO Model 16CF  
 Char-Lynn® 10,000 Series Wheel Motor

Char-Lynn is a registered trademark of Eaton Corporation.

**ALLOWABLE RADIAL LOAD vs LOAD POSITION**  
 BASED ON B10 LIFE OF BEARINGS

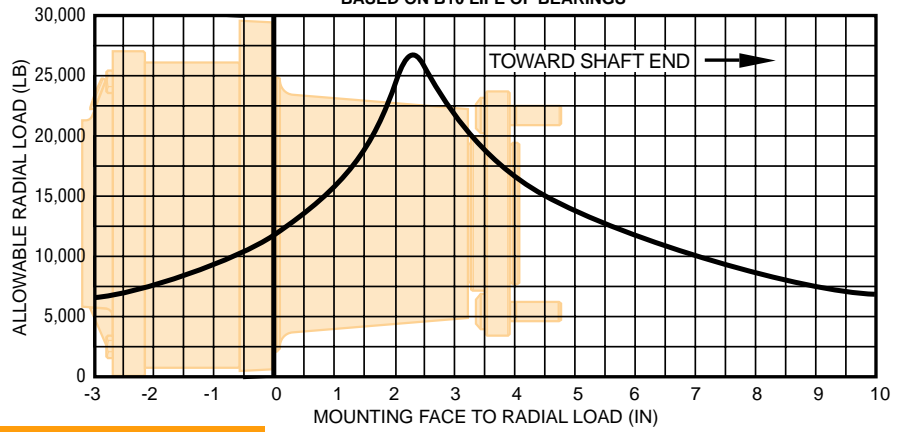

**FEATURE CHART: MODEL 6 "H" SERIES**  
**CENTER FLANGE SHAFT OUTPUT DRIVES -16CF**

OPTIONS	DESCRIPTION	MAKE ALL SELECTIONS WITHIN ONE COLUMN	ORDER CODES	USE OPTION ORDER CODES TO BUILD ORDER NUMBER
HUB CONFIGURATION	<b>CENTER FLANGE</b>	• • •	<b>6HCF</b>	<b>6HCF</b>
MOTOR PILOT	<b>SAE A2</b> <b>A4</b> <b>A5</b> <b>SAE B</b> <b>SAE C</b> <b>Char-Lynn 2000 Series Brgless</b>	• • • • • • • • •	<b>A2</b> <b>A4</b> <b>A5</b> <b>B</b> <b>C</b> <b>BC</b>	<b>BC</b>
INPUT SPLINE	<b>13T - 16/32</b> <b>14T - 12/24</b> <b>12T - 12/24</b> <b>1" - 6B</b>	• • • • • • • • •	<b>13</b> <b>14</b> <b>12</b> <b>6B</b>	<b>12</b>
RATIO * OPTIONS	<b>5.05:1</b>	• • •	<b>05</b>	<b>05</b>
OUTPUT SHAFTS	<b>2.25" Keyed Spindle Out</b>	• • • • • •	<b>K6</b> <b>F24</b>	<b>K6</b>
SPECIAL FEATURES	<b>Case Drain**</b>	• • •	<b>CD</b>	<b>CD</b>
Select desired characteristics from chart, note correct order codes, and order using sample format shown at right:				<b>6HCF BC 12 05 K6 CD</b>

Note: For vertical operation contact Auburn Gear.  
 \* Contact Auburn Gear for additional ratio availability.  
 \*\* If case drain is specified, this means that the hydraulic oil will be the lubrication medium for the gearing. With the CharLynn 2000 Series Bearingless Motor a seal is provided as standard to separate the gear lubricant from the hydraulic oil. If the case drain option is specified, this seal will be omitted.

**NOTE:**

These curves are supplied as a design guide and apply to resultant radial load only. They indicate the importance of maintaining load position over the bearing center. For actual analysis, applications should be reviewed by Auburn Gear Engineering using data supplied on Application Data Form.

**FOR OTHER VALUES OF LIFE DESIRED**  
**MULTIPLY ALLOWABLE LOAD READ**  
**FROM CURVE AS FOLLOWS:**

NUMBER OF REVOLUTIONS	LOAD MULTIPLIER
1.0 x 10 <sup>6</sup>	1.995
2.5 x 10 <sup>6</sup>	1.516
5.0 x 10 <sup>6</sup>	1.231
7.5 x 10 <sup>6</sup>	1.090
1.0 x 10 <sup>7</sup>	1.000
2.5 x 10 <sup>7</sup>	.760
5.0 x 10 <sup>7</sup>	.617
7.5 x 10 <sup>7</sup>	.546
1.0 x 10 <sup>8</sup>	.501

**MOTOR MOUNTING CHART**

MOTOR MOUNTING HOLE DIMENSIONS	DIAMETER "X"
<b>A2</b> (2) – .50 (12.7) -13 UNC,- 2B Thd Holes on 4.187 (106.35) B. C. diameter*	Ø 3.251 - 3.256 (82.58 - 82.70)
<b>A4, A5</b> (4) – .50 (12.7) -13 UNC,- 2B Thd Holes on 4.187 (106.35) B. C. diameter*	
<b>SAE B</b> (2) – .50 (12.7)-13 UNC,- 2B Thd Holes on 5.75 (146.1) B. C. diameter*	Ø 4.001 - 4.006 (101.62 - 101.75)
<b>Char-Lynn 2000</b> (4) - .50 (12.7) -13 UNC,- 2B Thd Holes on 5.000 (127.00) B. C. diameter*	Ø 4.001 - 4.006 (101.62 - 101.75)
<b>SAE C</b> (4) – .50 (12.7) -13 UNC,- 2B Thd Holes on 6.375 (161.93) B. C. diameter*	Ø 5.001 - 5.008 (127.02 - 127.15)
<b>OR</b> (2) – .625 (15.88) -13 UNC,- 2B Thd Holes on 7.125 (180.97) B. C. diameter*	

\*"O" RING OR GASKET REQUIRED (Not Supplied by Auburn Gear)  
 "O" RING SIZES: SAE "A" 2-042, SAE "B" 2-155, SAE "C" 2-159

**NOTE:**

The data presented in this catalog is for general information and preliminary layout purposes only. Auburn Gear, through its policy of continual improvement, reserves the right to update its products; therefore, the information presented is subject to change. For specific application and/or dimensional information, contact Auburn Gear.



# Model 6 Front Flange Shaft Output Drives - Single Reduction

## GENERAL SPECIFICATIONS

Max. continuous output torque <sup>1</sup> . 34,000 lb-in (3,800 Nm)	Approximate weight 6HFF .....	58 lbs (26.3 kg)
Max. output speed (RPM) .....	700	Approximate oil capacity .....
Max. radial shaft load .....	26,000 lb. (11,800 kg)	17 oz (500 cc)

<sup>1</sup> The maximum torque listed is a continuous torque based on a 2000 hour B10 life at output speeds less than the published maximum. It can be expected that applications requiring a combination of high output torque and high output RPM will result in shortened life. Contact Auburn Gear with your duty cycle information and we will supply life calculations for your specific application.

Dimensions given in: INCHES (mm)

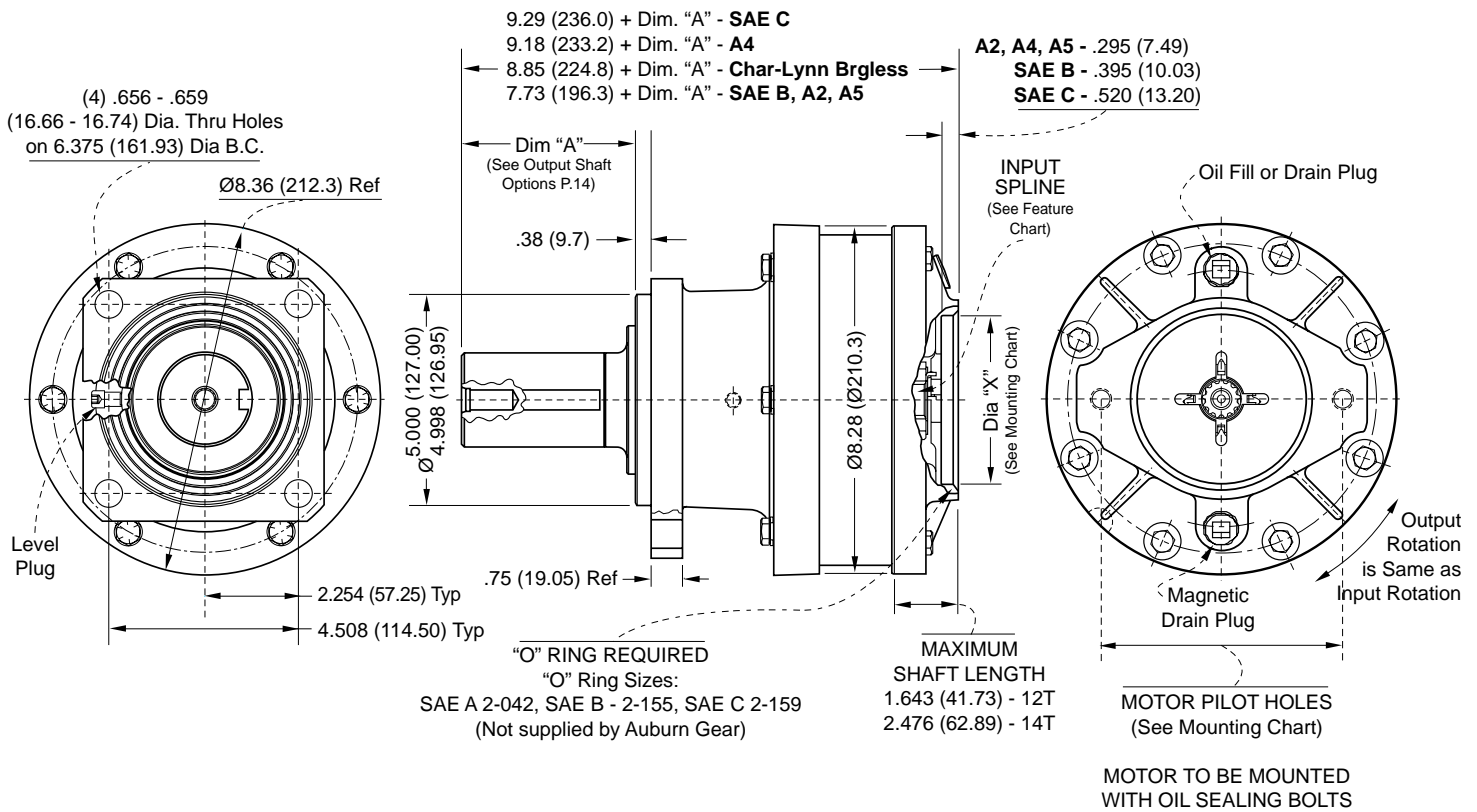

**Direct Interchange for:  
HECO Model 16FF  
Char-Lynn® 10,000 Series Standard Motor**



**ALLOWABLE RADIAL LOAD vs LOAD POSITION**  
BASED ON B10 LIFE OF BEARINGS

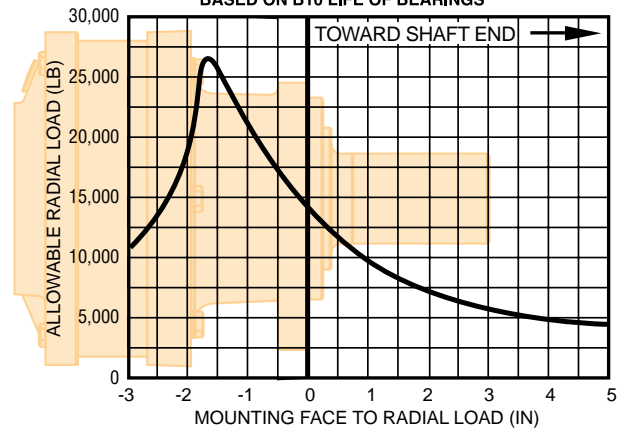

**NOTE:**

These curves are supplied as a design guide and apply to resultant radial load only. They indicate the importance of maintaining load position over the bearing center.

For actual analysis, applications should be reviewed by Auburn Gear Engineering using data supplied on Application Data Form.

**FEATURE CHART: MODEL 6 "H" SERIES FRONT FLANGE SHAFT OUTPUT DRIVES - 16FF**

OPTIONS	DESCRIPTION	MAKE ALL SELECTIONS WITHIN ONE COLUMN			ORDER CODES	USE OPTION ORDER CODES TO BUILD ORDER NUMBER		
HUB CONFIGURATION	<b>FRONT FLANGE</b>	•	•	•	<b>6HFF</b>	<b>6HFF</b>		
MOTOR PILOT	<b>SAE A2</b>	•			<b>A2</b>			
	<b>A4</b>		•		<b>A4</b>			
	<b>A5</b>			•	<b>A5</b>			
	<b>SAE B</b>	•			<b>B</b>			
	<b>SAE C</b>			•	<b>C</b>			
	<b>Charlynn 2000 Series Brgless</b>			•	<b>BC</b>	<b>BC</b>		
INPUT SPLINE	<b>13T - 16/32</b>	•			<b>13</b>			
	<b>14T - 12/24</b>		•		<b>14</b>			
	<b>12T - 12/24</b>			•	<b>12</b>		<b>12</b>	
	<b>1" - 6B</b>	•			<b>6B</b>			
RATIO* OPTIONS	<b>5.05:1</b>	•	•	•	<b>05</b>		<b>05</b>	
OUTPUT SHAFTS	<b>2.25" Keyed</b>	•	•	•	<b>K6</b>			<b>K6</b>
SPECIAL FEATURES	<b>Case Drain**</b>	•	•	•	<b>CD</b>			<b>CD</b>

Select desired characteristics from chart, note correct order codes, and order using sample format shown at right: **6HFF BC 12 05 K6 CD**

Note: For vertical operation contact Auburn Gear.

\* Contact Auburn Gear for additional ratio availability.

\*\* If case drain is specified, this means that the hydraulic oil will be the lubrication medium for the gearing. With the Charlynn 2000 Series Bearingless Motor a seal is provided as standard to separate the gear lubricant from the hydraulic oil. If the case drain option is specified, this seal will be omitted.

FOR OTHER VALUES OF LIFE DESIRED MULTIPLY ALLOWABLE LOAD READ FROM CURVE AS FOLLOWS:	
NUMBER OF REVOLUTIONS	LOAD MULTIPLIER
1.0 x 10 <sup>6</sup>	1.995
2.5 x 10 <sup>6</sup>	1.516
5.0 x 10 <sup>6</sup>	1.231
7.5 x 10 <sup>6</sup>	1.090
1.0 x 10 <sup>7</sup>	1.000
2.5 x 10 <sup>7</sup>	.760
5.0 x 10 <sup>7</sup>	.617
7.5 x 10 <sup>7</sup>	.546
1.0 x 10 <sup>8</sup>	.501

MOTOR MOUNTING CHART	
MOTOR MOUNTING HOLE DIMENSIONS	DIAMETER "X"
<b>A2</b> (2) – .50 (12.7) -13 UNC,- 2B Thd Holes on 4.187 (106.35) B. C. diameter*	Ø 3.251 - 3.256 (82.58 - 82.70)
<b>A4, A5</b> (4) – .50 (12.7) -13 UNC,- 2B Thd Holes on 4.187 (106.35) B. C. diameter*	
<b>SAE B</b> (2) – .50 (12.7)-13 UNC,- 2B Thd Holes on 5.75 (146.1) B. C. diameter*	Ø 4.001 - 4.006 (101.62 - 101.75)
<b>Char-Lynn 2000</b> (4) - .50 (12.7) -13 UNC,- 2B Thd Holes on 5.000 (127.00) B. C. diameter*	Ø 4.001 - 4.006 (101.62 - 101.75)
<b>SAE C</b> (4) – .50 (12.7) -13 UNC,- 2B Thd Holes on 6.375 (161.93) B. C. diameter*	Ø 5.001 - 5.008 (127.02 - 127.15)
<b>OR</b> (2) – .625 (15.88) -13 UNC,- 2B Thd Holes on 7.125 (180.97) B. C. diameter*	

\*"O" RING OR GASKET REQUIRED (Not Supplied by Auburn Gear)  
"O" RING SIZES: SAE "A" 2-042, SAE "B" 2-155, SAE "C" 2-159

**NOTE:**

The data presented in this catalog is for general information and preliminary layout purposes only. Auburn Gear, through its policy of continual improvement, reserves the right to update its products; therefore, the information presented is subject to change. For specific application and/or dimensional information, contact Auburn Gear.

# Model 8 Center Flange Shaft Output Drives - Single and Double Reductions

## GENERAL SPECIFICATIONS

<p>Max. continuous output torque<sup>1</sup> . 80,000 lb-in (9,000 Nm)</p> <p>Max. output speed (RPM)</p> <p>..... Single Reduction Ratios - 600</p> <p>..... Double Reduction Ratios - 160</p> <p>Max. radial shaft load ..... 32,000 lb. (14,500 kg.)</p>	<p>Approximate oil capacity</p> <p>..... Single Reduction 38 oz (1,125 cc)</p> <p>..... Double Reduction 42 oz (1,250 cc)</p> <p>Approximate weight</p> <p>..... 8HCF Single Reduction 119 lbs (54.0 kg)</p> <p>..... 8HCF Double Reduction 155 lbs (70.3 kg)</p>
---	---

<sup>1</sup> The maximum torque listed is a continuous torque based on a 2000 hour B10 life at output speeds less than the published maximum. It can be expected that applications requiring a combination of high output torque and high output RPM will result in shortened life. Contact Auburn Gear with your duty cycle information and we will supply life calculations for your specific application.

Dimensions given in: INCHES (mm)

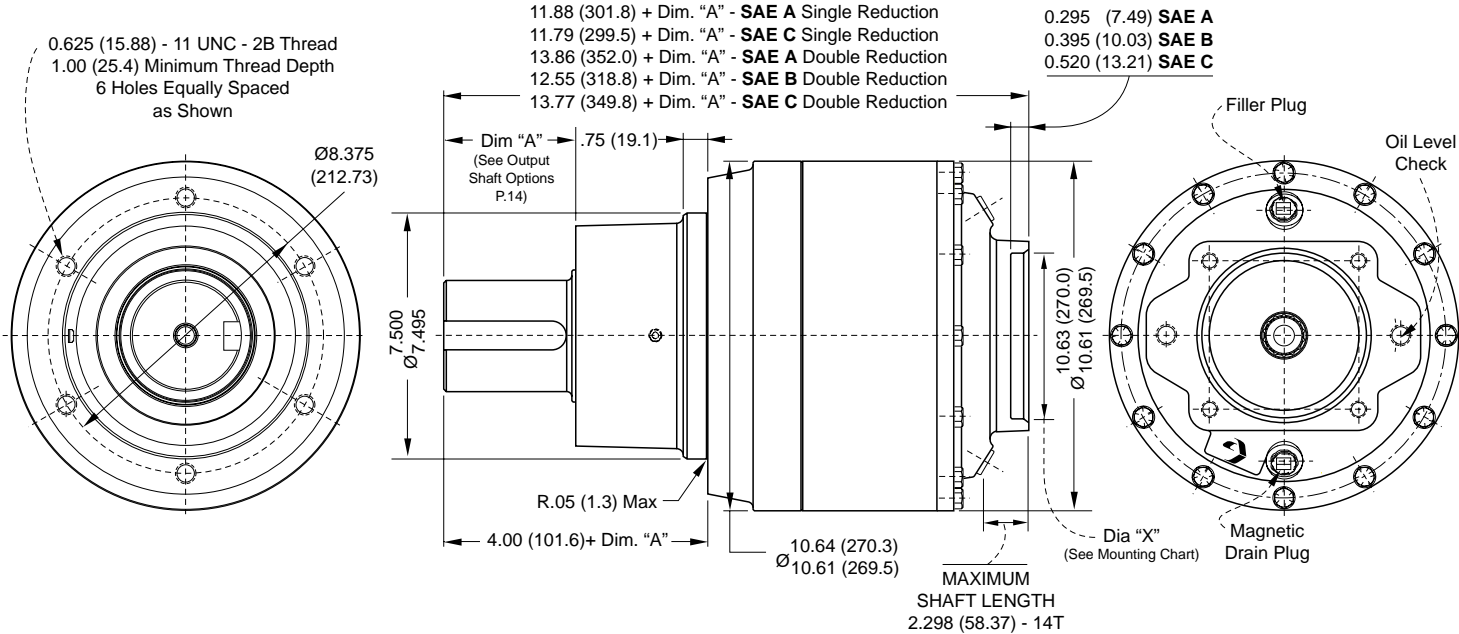

Direct Interchange for:  
 HECO Model 20CF  
 HECO Model 20DCF

**ALLOWABLE RADIAL LOAD vs LOAD POSITION**  
 BASED ON B10 LIFE OF BEARINGS

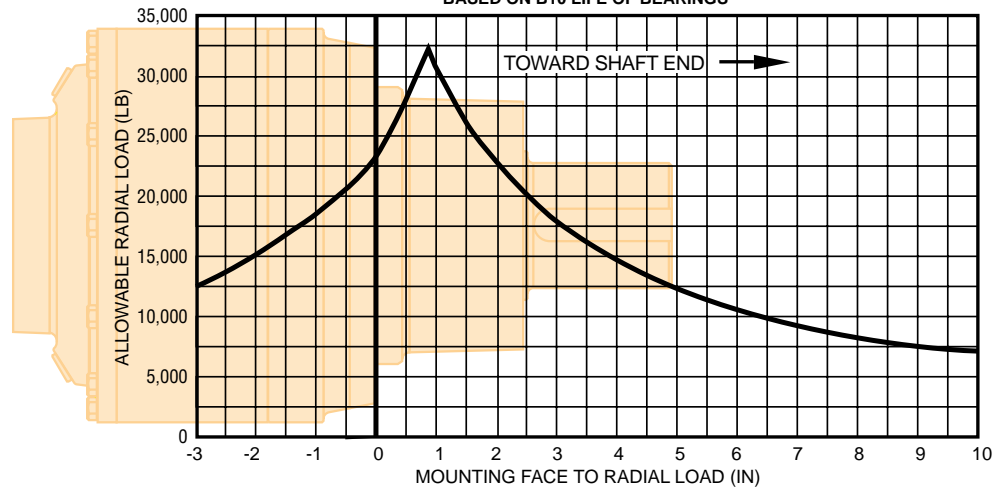

**NOTE:**

These curves are supplied as a design guide and apply to resultant radial load only. They indicate the importance of maintaining load position over the bearing center.

For actual analysis, applications should be reviewed by Auburn Gear Engineering using data supplied on Application Data Form.

**FEATURE CHART: MODEL 8 “H” SERIES CENTER FLANGE SHAFT OUTPUT DRIVES - 20CF & 20DCF**

OPTIONS	DESCRIPTION	MAKE ALL SELECTIONS WITHIN ONE COLUMN		ORDER CODES	USE OPTION ORDER CODES TO BUILD ORDER NUMBER				
HUB CONFIGURATION	<b>CENTER FLANGE</b>	•	•	<b>8HCF</b>	<b>8HCF</b>				
MOTOR PILOT	<b>SAE A</b> <b>SAE B</b> <b>SAE C</b>	•	•	<b>A</b> <b>B</b> <b>C</b>		<b>B</b>			
INPUT SPLINE	<b>13T - 16/32</b> <b>14T - 12/24</b>	•	•	<b>13</b> <b>14</b>		<b>13</b>			
RATIO* OPTIONS	<b>4.86:1**</b> <b>6.00:1**</b> <b>23.59:1</b> <b>26.71:1</b> <b>31.50:1</b>	•	•	<b>04</b> <b>06</b> <b>23</b> <b>26</b> <b>31</b>			<b>04</b>		
OUTPUT SHAFTS	<b>2.750" Keyed</b> <b>3.375" Keyed</b>	•	•	<b>K3</b> <b>K4</b>			<b>K3</b>		
Select desired characteristics from chart, note correct order codes, and order using sample format shown at right.					<b>8HCF</b>	<b>B</b>	<b>13</b>	<b>04</b>	<b>K3</b>

Note: For vertical operation contact Auburn Gear.

\* Contact Auburn Gear for additional ratio availability.

\*\* Single reduction ratios; all others are double reduction.

**FOR OTHER VALUES OF LIFE DESIRED  
 MULTIPLY ALLOWABLE LOAD READ  
 FROM CURVE AS FOLLOWS:**

NUMBER OF REVOLUTIONS	LOAD MULTIPLIER
1.0 x 10 <sup>6</sup>	1.995
2.5 x 10 <sup>6</sup>	1.516
5.0 x 10 <sup>6</sup>	1.231
7.5 x 10 <sup>6</sup>	1.090
1.0 x 10 <sup>7</sup>	1.000
2.5 x 10 <sup>7</sup>	.760
5.0 x 10 <sup>7</sup>	.617
7.5 x 10 <sup>7</sup>	.546
1.0 x 10 <sup>8</sup>	.501

**MOTOR MOUNTING CHART**

MOTOR MOUNTING HOLE DIMENSIONS	DIAMETER “X”
<b>SAE A, A1</b> (4) – .500 (12.70) -13 UNC 2B Thd Holes on 4.188 (106.38) B. C.	Ø 3.251 - 3.256 (82.58 - 82.70)
<b>SAE B, B1</b> (2) – .500 (12.70) -13 UNC 2B Thd Holes on 5.750 (146.05) B. C.	Ø 4.001 - 4.006 (101.62 - 101.75)
<b>SAE C, C1</b> (4) – .500 (12.70) -13 UNC 2B Thd Holes on 6.375 (161.93) B. C.	Ø 5.001 - 5.006 (127.02 - 127.15)
<b>OR</b> (2) – .625 (15.88) -11 UNC 2B Thd Holes on 7.125 (180.98) B. C.	

\*“O” RING OR GASKET REQUIRED (Not Supplied by Auburn Gear)

“O” RING SIZES: SAE “A” 2–042, SAE “B” 2–155, SAE “C” 2–159

**NOTE:**

The data presented in this catalog is for general information and preliminary layout purposes only. Auburn Gear, through its policy of continual improvement, reserves the right to update its products; therefore, the information presented is subject to change. For specific application and/or dimensional information, contact Auburn Gear.

# Model 8 Front Flange Shaft Output Drives - Single and Double Reductions

## GENERAL SPECIFICATIONS

Max. continuous output torque <sup>1</sup> . 80,000 lb-in (9,000 Nm)	Approximate oil capacity
Max. output speed (RPM)	..... Single Reduction 38 oz (1,125 cc)
..... Single Reduction Ratios -600	..... Double Reduction 42 oz (1,250 cc)
..... Double Reduction Ratios -160	Approximate weight
Max. radial shaft load ..... 32,000lbs (14,500 kg)	..... 8HFF Single Reduction 135 lbs (61.2 kg)
	..... 8HFF Double Reduction 170 lbs (77.1 kg)

<sup>1</sup> The maximum torque listed is a continuous torque based on a 2000 hour B10 life at output speeds less than the published maximum. It can be expected that applications requiring a combination of high output torque and high output RPM will result in shortened life. Contact Auburn Gear with your duty cycle information and we will supply life calculations for your specific application.

Dimensions given in: INCHES (mm)

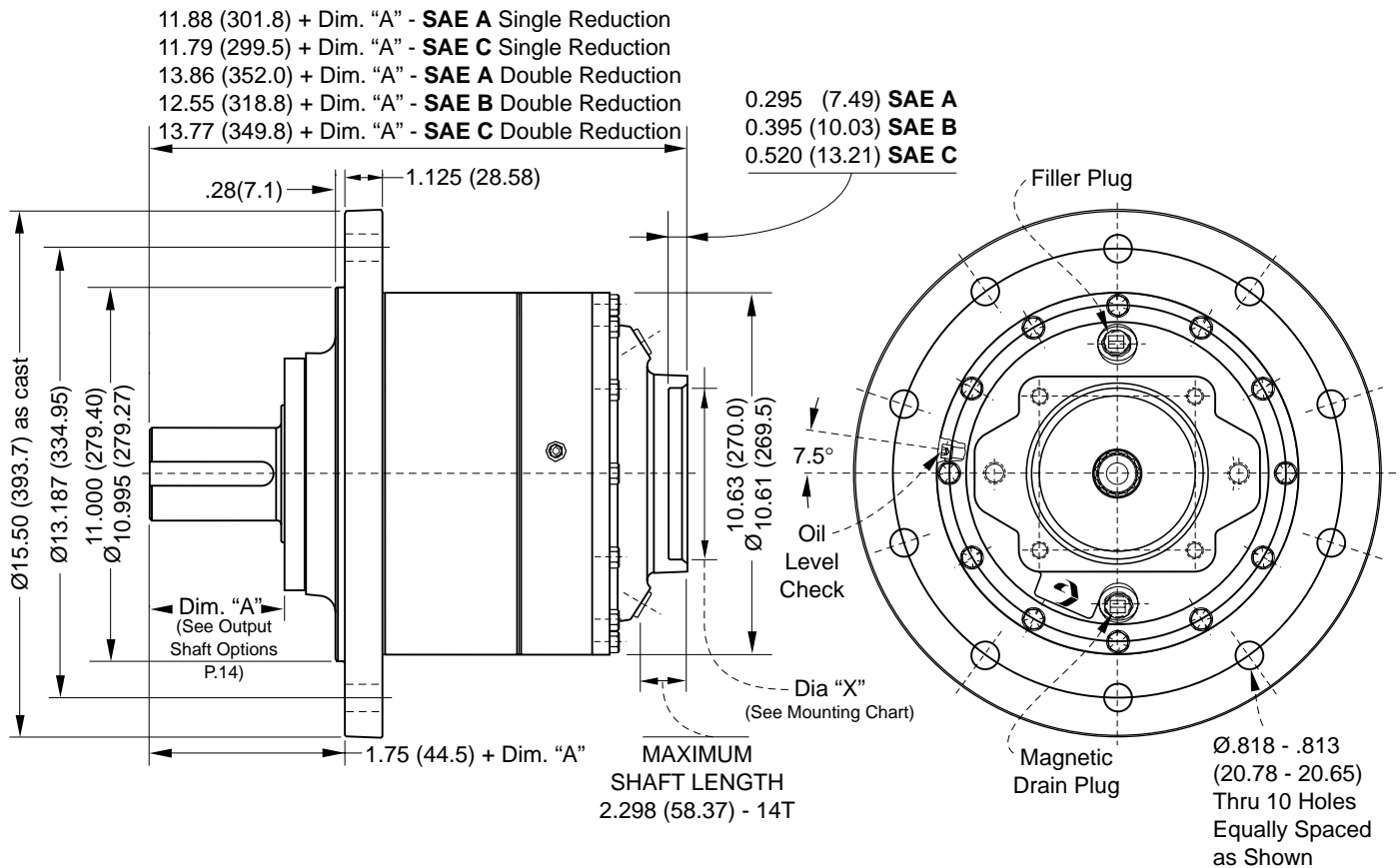

**Direct Interchange for:  
 HECO Model 20FF  
 HECO Model 20DFF**

**ALLOWABLE RADIAL LOAD vs LOAD POSITION**  
 BASED ON B10 LIFE OF BEARINGS

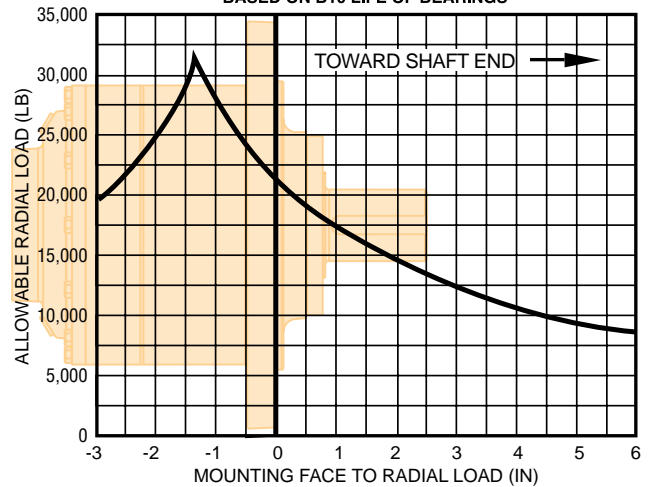

**NOTE:**

These curves are supplied as a design guide and apply to resultant radial load only. They indicate the importance of maintaining load position over the bearing center.

For actual analysis, applications should be reviewed by Auburn Gear Engineering using data supplied on Application Data Form.

**FEATURE CHART: MODEL 8 "H" SERIES FRONT FLANGE SHAFT OUTPUT DRIVES - 20FF & 20DF**

OPTIONS	DESCRIPTION	MAKE ALL SELECTIONS WITHIN ONE COLUMN		ORDER CODES	USE OPTION ORDER CODES TO BUILD ORDER NUMBER				
HUB CONFIGURATION	<b>FRONT FLANGE</b>	•	•	<b>8HFF</b>	<b>8HFF</b>				
MOTOR PILOT	<b>SAE A</b> <b>SAE B</b> <b>SAE C</b>	•	•	<b>A</b> <b>B</b> <b>C</b>		<b>B</b>			
INPUT SPLINE	<b>13T - 16/32</b> <b>14T - 12/24</b>	•	•	<b>13</b> <b>14</b>		<b>13</b>			
RATIO* OPTIONS	<b>4.86:1**</b> <b>6.00:1**</b> <b>23.59:1</b> <b>26.71:1</b> <b>31.50:1</b>	•	•	<b>04</b> <b>06</b> <b>23</b> <b>26</b> <b>31</b>			<b>04</b>		
OUTPUT SHAFTS	<b>2.750" Keyed</b> <b>3.375" Keyed</b>	•	•	<b>K3</b> <b>K4</b>			<b>K3</b>		
Select desired characteristics from chart, note correct order codes, and order using sample format shown at right:					<b>8HFF</b>	<b>B</b>	<b>13</b>	<b>04</b>	<b>K3</b>

Note: For vertical operation contact Auburn Gear.

\* Contact Auburn Gear for additional ratio availability.

\*\* Single reduction ratios; all others are double reduction.

**FOR OTHER VALUES OF LIFE DESIRED  
 MULTIPLY ALLOWABLE LOAD READ  
 FROM CURVE AS FOLLOWS:**

NUMBER OF REVOLUTIONS	LOAD MULTIPLIER
1.0 x 10 <sup>6</sup>	1.995
2.5 x 10 <sup>6</sup>	1.516
5.0 x 10 <sup>6</sup>	1.231
7.5 x 10 <sup>6</sup>	1.090
1.0 x 10 <sup>7</sup>	1.000
2.5 x 10 <sup>7</sup>	.760
5.0 x 10 <sup>7</sup>	.617
7.5 x 10 <sup>7</sup>	.546
1.0 x 10 <sup>8</sup>	.501

**MOTOR MOUNTING CHART**

MOTOR MOUNTING HOLE DIMENSIONS	DIAMETER "X"
<b>SAE A, A1</b> (4) – .500 (12.70) -13 UNC 2B Thd Holes on 4.188 (106.38) B. C.	Ø 3.251 - 3.256 (82.58 - 82.70)
<b>SAE B, B1</b> (2) – .500 (12.70) -13 UNC 2B Thd Holes on 5.750 (146.05) B. C.	Ø 4.001 - 4.006 (101.62 - 101.75)
<b>SAE C, C1</b> (4) – .500 (12.70) -13 UNC 2B Thd Holes on 6.375 (161.93) B. C.	Ø 5.001 - 5.006 (127.02 - 127.15)
<b>OR</b> (2) – .625 (15.88) -11 UNC 2B Thd Holes on 7.125 (180.98) B. C.	

\*"O" RING OR GASKET REQUIRED (Not Supplied by Auburn Gear)  
 "O" RING SIZES: SAE "A" 2-042, SAE "B" 2-155, SAE "C" 2-159

**NOTE:**

The data presented in this catalog is for general information and preliminary layout purposes only. Auburn Gear, through its policy of continual improvement, reserves the right to update its products; therefore, the information presented is subject to change. For specific application and/or dimensional information, contact Auburn Gear.

# Model 6 Shaft Output Options

**F24**

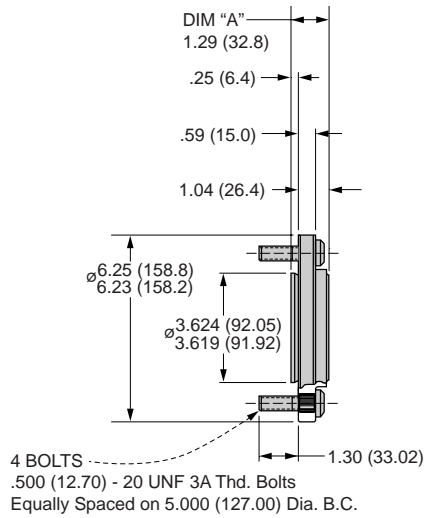

**K6**

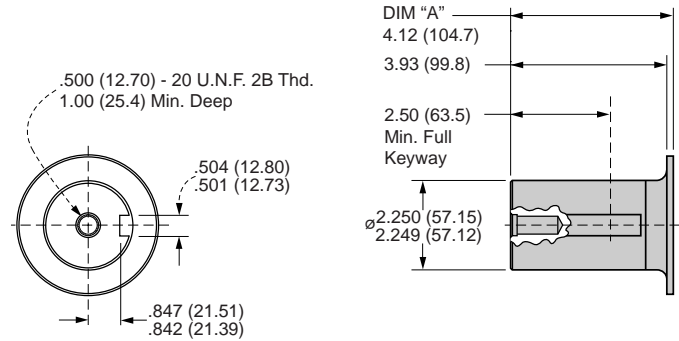

# Model 8 Shaft Output Options

**K3**

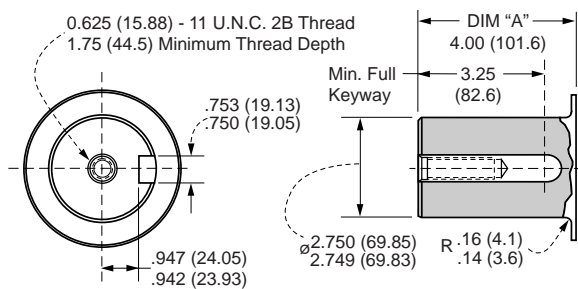

**K4**

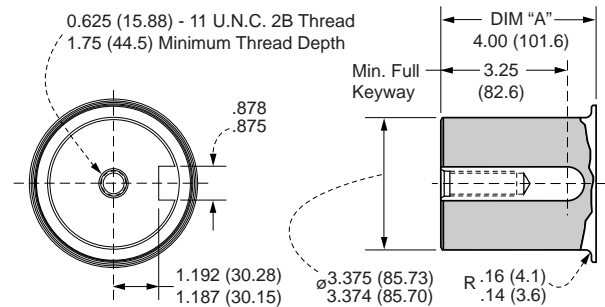

# Lubrication Data

Power Wheel Planetary Drives are shipped without lubricant and must be filled to the proper level prior to start-up.

**1. Type**

In normal applications use an extreme pressure lubricant API-GL-5 approved. AGI recommends SAE 80W, 90, 80W-90 and 85W-90 grades of lube under normal climate and operating conditions. See chart below. For severe or abnormal applications with special requirements consult either Auburn Gear or a lubricant manufacturer for further assistance.

**2. Change Interval**

Initial lubrication change after 50 hours of operation. Subsequent changes every 1000 hours or yearly whichever comes first.

**3. Lube Temperature**

Continuous operating temperatures of 160°F are allowable. Maximum intermittent temperature recommended is 200°F.

**4. Amount of Lube**

The unit should be half full when mounted horizontal. Lube levels for other mounts will vary. Consult Auburn Gear for details.

**5. Shaft or Spindle Up Mounting**

If mounting unit vertically with shaft or spindle up, special provisions apply to ensure adequate lubrication of output bearings. Consult Auburn Gear.

Auburn Gear Power Wheel Low Temperature Gear Lube Requirement	
SAE Viscosity Grade	Auburn Gear Recommended Minimum Temperature
75W-90	-40°F (-40°C)*
80W, 80W-90	-15°F (-26°C)*
85W, 85W-90	10°F (-12°C)*
90	35°F (2°C)

\* Maximum temperature for Brookfield Viscosity<sup>1</sup> of 150,000 centipoise (cP)<sup>2</sup> per SAE J306 MAR85

<sup>1</sup> Brookfield Viscosity - *apparent viscosity* as determined under ASTM D 2983

<sup>2</sup> 150,000 cP determined to provide sufficient low temperature lube properties for Auburn Gear Power Wheels

# Warranty Information

## Power Wheel® Warranty

Seller warrants to Purchaser that its Power Wheel® planetary gear products are free from defects in material and workmanship under normal use and service for a period of one year from the date the product is shown to have been placed into operation by original user or for two years from date of shipment from seller's plant, whichever shall first occur.

Seller's obligation under this warranty is expressly limited to the repair or replacement at its option, of the Power Wheel which is returned with a written claim of defect f.o.b. seller's factory, Auburn, Indiana, U.S.A., and which is determined by Seller to be defective in fact.

THIS IS THE SOLE AND ONLY WARRANTY OF SELLER AND NO OTHER WARRANTY IS APPLICABLE, EITHER EXPRESSED OR IMPLIED, IN FACT OR BY LAW, INCLUDING ANY WARRANTY AS TO MERCHANTABILITY OR FITNESS FOR A PARTICULAR USE OR PURPOSE.

The sole and only remedy in regard to any defective Power Wheel shall be the repair or replacement thereof herein provided, and seller shall not be liable for any consequential, special, incidental, or punitive damages, losses or expenses resulting from or caused by any defects.

AUBURN GEAR, INC.

AUBURN, INDIANA, U.S.A.

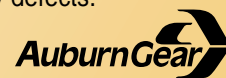





400 East Auburn Drive  
Auburn, Indiana 46706-3499 • USA  
PH: (219) 925-3200  
FAX: (219) 925-4725  
E-mail: [auburngear@mail.fwi.com](mailto:auburngear@mail.fwi.com)  
Web: <http://www.auburngear.com>

*All specifications and data contained herein are nominal and subject to change without notice.  
Specific applications should be referred to Auburn Gear for current information.*